

---

## DESIGN OF INCLINED METERING MECHANISM BASED ON SOWDWORKS

---

**MANISHA SAHU**

Department of Farm  
Machinery and Power Engineering  
IGKV University, Raipur

**AJAY VERMA**

Department of Farm  
Machinery and Power Engineering  
IGKV University, Raipur

**LEKH SONI**

Department of Mechanical Engineering  
Sri Rawatpura Sarkar Institute of Technology  
New Raipur

---

**ABSTRACT:** In the paper, the necessity of mechanized rain fed rice cultivation and direct seeding of paddy was put forward from the perspective of cost utilization. To accomplish mechanized direct seeding of paddy, an inclined metering mechanism was designed based on parametric modeling software Solidworks. Firstly parts were built under entity modeling module, and then metering mechanism was assemble in assembling environment. Secondly, mechanisms including frame, seed box, transmission mechanism and metering mechanism were assembled together to establish the whole prototype on which interference checking was done. Through manual change of transmission pulley installation position, the metering mechanism was able to sowing of seeds with in different spacing as we required to different varieties. Finally, relevant 2-D engineering drawings were generated for manufacture. The paper provides methodological reference for the design of similar metering mechanism with setup and preparation for further simulation and analysis of the designed models.

**KEYWORDS:** inclined plate, kinematic motion, solidworks, and virtual design.

---

### INTRODUCTION

Rice is most prominent crop in India and is the staple food fulfilling 43% of the caloric requirement of majority of the Indian population. Designing process on hole wheel seed meter using three-dimensional feature modeling software solid works and dynamic simulation of assembling process and conjunctional production of two dimensional drawing were conducted (Yang Wenmim et al. 2006).

In the study, Solidworks 2009 was applied for the design of inclined pate metering mechanism. Three dimensional models of seed metering device parts are accomplished by Solid-works software applying down-up design rule. The metering plate is kept inclined at  $60^\circ$  to the horizontal (Sahoo and Shrivastav, 2000; Kamble et al., 2003). Falling process of seed in seed metering device is simulated for ascertaining optimal seed speed and rotatable speed. Theory gist of parameter design and optimal design is provided for inclined seed metering device. It's an incredible tool that has let us save 30 to 60 percent in capital costs in the development of new products.

### CHARACTERISTICSS OF SOLIDWORKS

Solidworks is the first 3 dimensional CAD software developed on windows operating system, and due to its powerful functions, characteristics of easy to learn and easy to use, it s widely applied in mechanical design. With parametric feature modeling technology, different entities can be created, meeting most requirements of engineering design; with single internal database, all data is related with each other, modifications on dimension in any module will automatically reflect in other modules; in 3 dimensional assembly modules, transmission relationship between components can be dynamically simulated. Solidworks is especially suitable for product development, as it is able to shorten product design cycle, improve design quality and reduce cost. Solidworks has become one o the mainstream software in mechanical design and modeling (Zhou Dashuai et al., 2006).

## MATERIALMAND METHOD DESIGN PROCESS OF INCLINED METERING MECHANISM USING SOLIDWORKS SCHEME DESIGN:

The experimental setup consists of frame, transmission gear, metering mechanism seedbox. The tractor drawn inclined plate planter was hitched to tractor with 3 point hitch. During the operation, forward speed of tractor was transmitted by the conveyor to the metering mechanism by ground wheel. Then via chain sprocket and bevel-shaft, the power was transmitted to bevel gear pair. Finally, the bevel gear pair had driven the inclined plate metering mechanism.

Kinematic motion of the metering mechanism was inclined on the basis of angle of repose of paddy seeds. It rotated around the shaft of bevel gear. During the rotation of metering mechanism two to three seeds of paddy pickup by the each cell of the plate and dropped it to the seed tube trough the funnel. These seed was dropped on the conveyor belt. The velocity of these seeds of continues cells are used to calculate the seed to seed spacing Fig 1.

### SEED METERING PLATE AND PARTS DESIGN:

Cell of metering plate was designed on the basis of average physical properties of prominent varieties of the paddy available in local area of Chhattisgarh. Four varieties of rice viz: (*Oryza Sativa L.*) viz. *Indira Barani* (V1), *IGKV R2* (V2) and *MTU- 1010* (V3), *Mahamaya* (V4) were selected and found there average length, width thickness, sphericity, thousand seeds weight, bulk density angle of repose and moisture content was 9.27 cm, 2.43 cm, 2.15 cm, 0.38, 27 g, 535.76 kg/m<sup>3</sup>, 37.06° and 15.40 %db, respectively. The half distance of the minor axis of the cell of the plate was chosen 10% more than half breadth of the seed by [1].

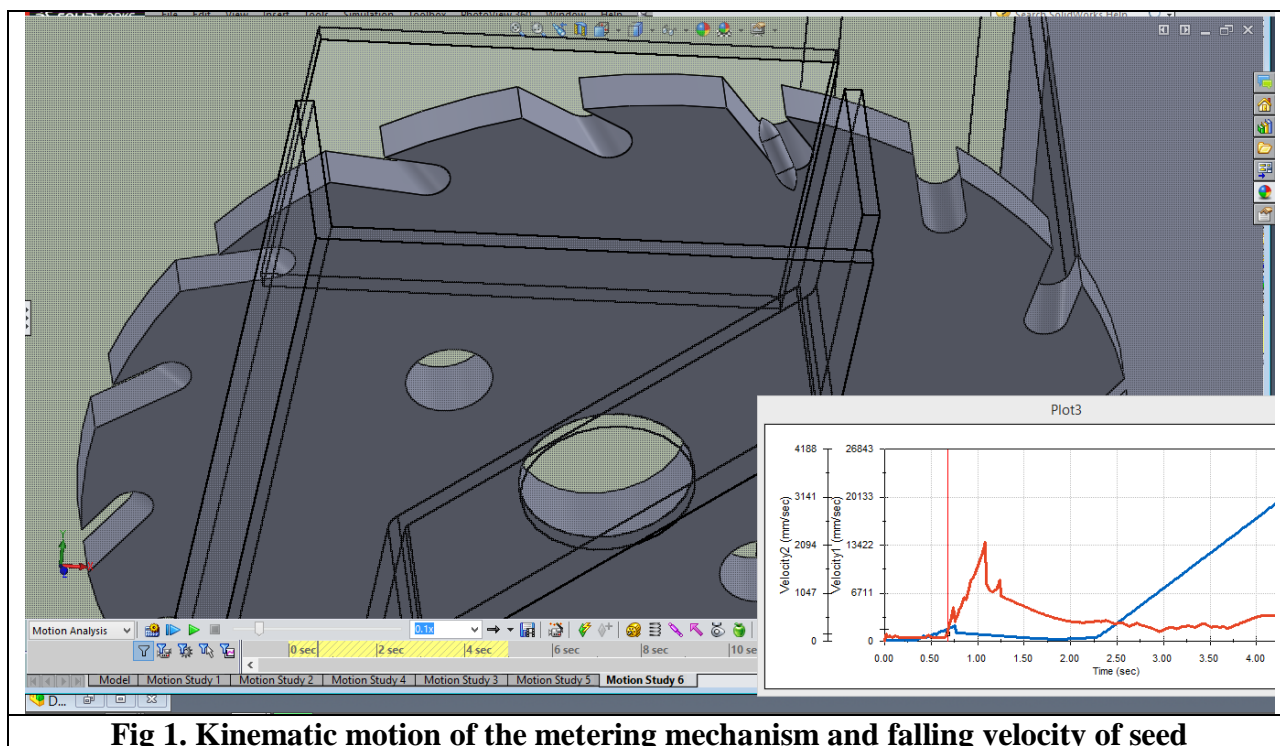

**Fig 1. Kinematic motion of the metering mechanism and falling velocity of seed**

Design of inclined plate metering mechanism is the basis of 3 dimensional virtual design. In solidworks, features are created from ways such as extrude, revolve, array etc., and then combined together according to constraint relations to form the experimental setup of metering mechanism. For example, the creating process of the bevel gear used in the experimental setup was: create the basic feature by revolving the 2-D sketch around an axis (revolve) – create gear groove by removing material between the two profiles (loft-cut) – array gear groove around the axis (circular pattern) – create hole and keyway by cutting material (extrude-cut) – complete.

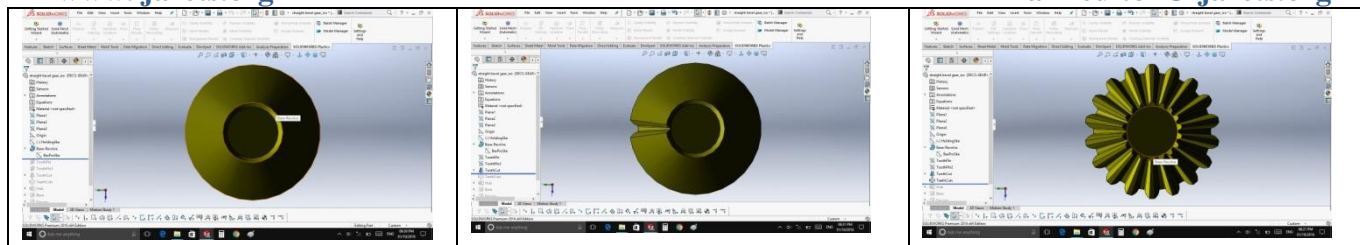

**Fig.2 Sketch of bevel and pinion gear**

Parts of the experimental setup were created one by one and then saved in the same file folder, as this would make the file management more convenient especially in the subsequent assembly manipulation. During the design process, relationships among features must be taken into account. Generally, according to the order in which features are created, features and their relationships are listed in Feature Manager Design tree on the left side of the interface. And for the convenience of feature modification, models can be zoomed in and out, freely rotated, hidden and suppressed.

**EXPERIMENTAL SETUP DESIGN**

**ASSEMBLY DESIGN:**

After experimental setup parts design was completed, components and necessary mates were inserted into assembly environment to form assembly models. Mates create geometric relationships between assembly components and define spatial position of one component relating to another. There are many mate types available in Solidworks such as coincide, parallel, perpendicular, tangent, concentric, and so on. For the experimental setup, according to the function of each mechanism, parts were assembled. Thus parts having frame, seedbox, transmission mechanism and metering mechanism. The metering mechanism and whole assembly were shown in Fig 3 and 4, respectively.

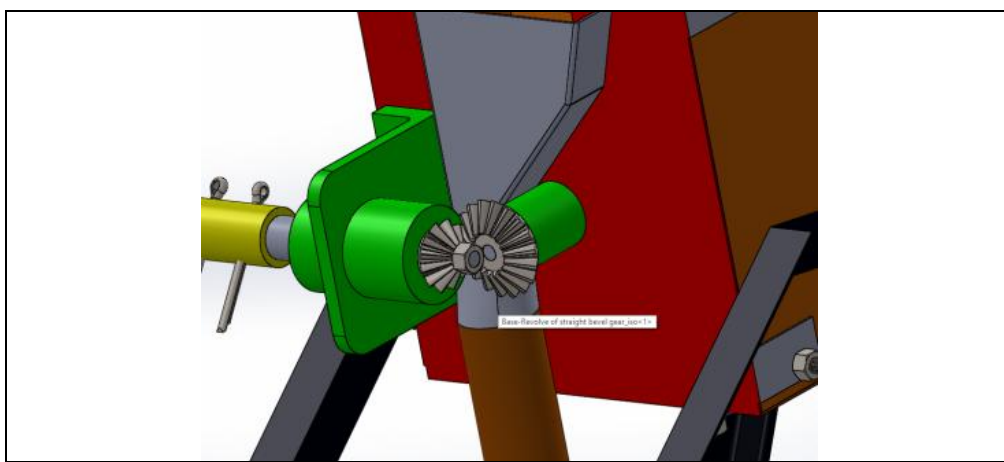

**Fig.3 Assembly design of bevel and pinion gear**

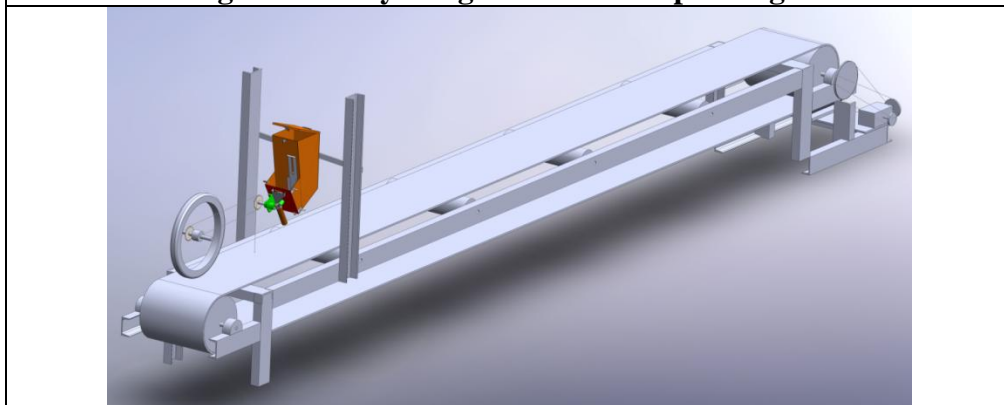

**Fig.4 Whole assembly of experimental lab-setup in solid works**

**RESULTS AND DISCUSSION INTERFERENCE DETECTION**

Interference detection is one of the most important functions of Solidworks which can rapidly determine whether there is any interference between components and between sub-assemblies (a sub-assembly is treated as a single component). Here, the whole assembly was checked for interference, and according to analysis results, relevant details of parts and constraint settings between components were modified. The procedure was repeated until there wasn't any interference, as shown in Fig.5.

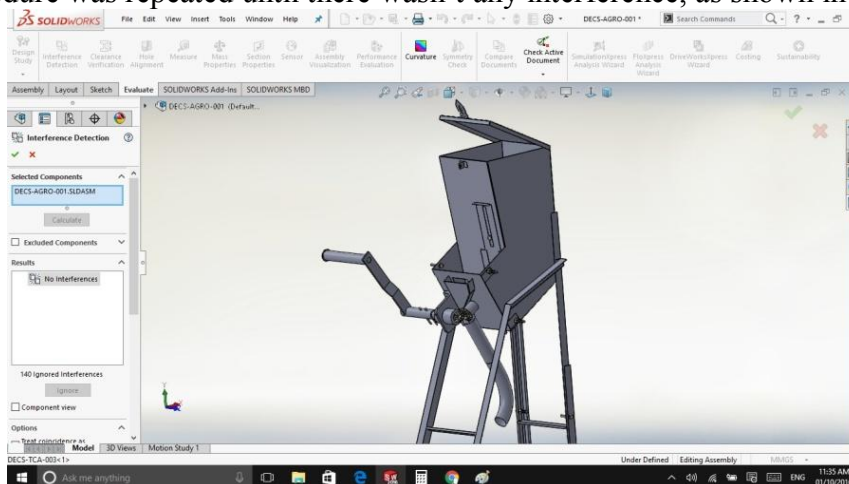

**Fig. 5. Interference detection on the machine**

**GENERATION OF 2-D ENGINEERING:**

After above steps, 2-D engineering drawings were generated from corresponding parts and assemblies in the drawing module, and automatic dimensioning was done in each drawing. Noted that 3-D models and 2-D engineering drawings were related with each other, namely and modification of dimensions made in 3-D part and assembly module would be reflected in drawing module and vice versa. Some necessary annotations such as weld symbol, geometric tolerance, surface finish symbol and BOM (Bill of Material), etc. were inserted into drawings as these were required for manufacture. Completed engineering drawings were saved in default file format of Solidworks and DWG format which was recognizable by AutoCAD. 2-D projection drawing of the whole experimental setup was shown in Fig.6.

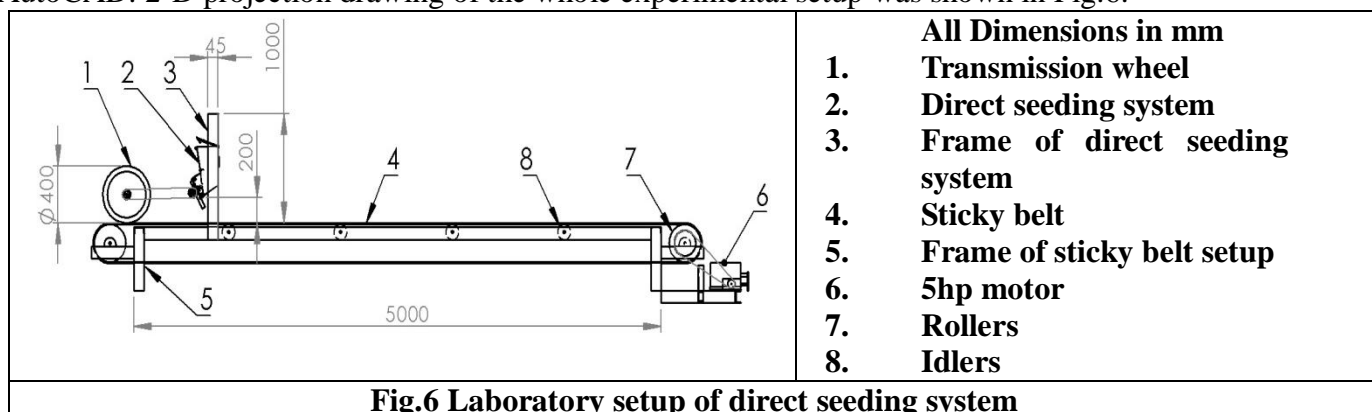

**Fig.6 Laboratory setup of direct seeding system**

**CONCLUSIONS**

1. The necessity of mechanized rain fed rice cultivation and direct seeding of paddy was put forward from the perspective of cost utilization, considering the average physical properties of prominent varieties of the paddy available in local area of Chhattisgarh.
2. Solidworks was applied to accomplish part design, assembly design, interference detection and generation of 2-D engineering drawings. Results showed that the design was reasonable and feasible.



3. The created metering mechanism, parts and assembly will be models for subsequent simulation and analysis I necessary. The study provides theoretical foundations and methodological references for the application o virtual prototype technology on the development of new agricultural machinery.

#### **ACKNOWLEDGEMENTS**

The research is supported by NAE (FMIR) ICAR for funding the project, SVCAET & RS, Faculty of Agricultural Engineering, IGKV University, and Raipur.

#### **REFERENCES**

1. Anantachara, M. G.V. Kumarb, Prasanna. Guruswamy, T. Neural Network Prediction of Performance Parameters of an Inclined Plate Seed Metering Device and its Reverse Mapping for the Determination of Optimum Design and Operational Parameters. *Computers and Electronics in Agriculture* 72 87–98 (2010).
2. Kamble, A.K., Rahate, R.H., Devagirikar, A.A., Diwane, L.P., Alurkar, H.P. Development evaluation of multipower operational cotton planter. *Bioved* 14 (1/2), 29–32 (2003).
3. Sahoo, P.K., Srivastava, A.P. Development of performance evaluation of okra planter. *J. Agric. Eng.*, 15–25 (2000).
4. YANG Wen-min a, GUAN Chun-yun b, WU Ming-liang a, CHEN She-yuan b, TANG Chu-zhou. Feature Modeling and Assembling Conjunction Design on Precision Seeder by Software Solidworks. *Journal of Agricultural Mechanization Research*; -03 110-113 (2006).
5. Zhou Dashuai, Liuxiangdong, Lu Wei. Application of Solidworks Software on the Design of Agricultural Machinery. *Journal, Modernizing Agriculture* (10). 42-43 (2006)